

LCD Indicator Control Module Product Data Sheet

Model Name: **QCM-200AS2RS** Rev.A1

Contents

Introduction _____ Page 1

- Feature
- Product Photo

Function / Specification

- LCD Spec. _____ Page 2
- Electronic Feature _____ Page 2

Hardware Descriptions

- PCB Diagram _____ Page 3
- Jumpers / Connectors Description _____ Page 3
- PCB Dimension Diagram _____ Page 4

Hardware Operation Instructions

- Starting Screen _____ Page 5
- Horizontal Display Description for Fl. Position _____ Page 5
- Vertical Display Description for Fl. Position _____ Page 5
- Style Position Display Description _____ Page 6
- Data Transmission Screen description _____ Page 7

Hwan Maw Technology Co., Ltd.

Tel.: +886-2-2274-1347 Fax. +886-2-2273-3014

[Http://www.hmt.com.tw](http://www.hmt.com.tw) e-mail: hmtsales@hmt.com.tw

LCD Indicator Control Module Product Data Sheet

Model Name: **QCM-200AS2RS** Rev.A1

Contents

Software Operation Instructions

- Software Information _____ Page 8
- QCM-200AS2 Lift LCD Editor Interface _____ Page 8
- QCM-200AS2 Lift LCD Editor Operation _____ Page10

Housing Descriptions

- Dimension for QCM-200AS2RS _____ Page13

Product Information

- QCM-200AS2RS _____ Page14

Hwan Maw Technology Co., Ltd.

Tel.: +886-2-2274-1347 Fax. +886-2-2273-3014

[Http://www.hmt.com.tw](http://www.hmt.com.tw) e-mail: hmtsales@hmt.com.tw

LCD Indicator Control Module Product Data Sheet

Model Name: **QCM-200AS2RS** Rev.A1

Introduction

QCM-200AS2RS LCD Indicator Control Module is designed innovatively to be configured into elevators. Different from LED matrix and 7-segment indicators, QCM-200AS2RS can select the up / down icons and number styles via PC, displaying fixed simple messages like the company title or the name of the building...etc.

QCM-200AS2RS LCD Indicator Control Module can display horizontally or vertically. Via RS-232 interface, all settings can be done by the tool software after downloading as well as written into FLASHROM; For color display, adopt white color words / icons on a blue background or a bright black one. Configured to the elevator car or hall, it boosts not only the additional value of products but also its superior quality.

Feature

- * Adopt LED back-lighted module with excellent durability. Power saving mode setting is provided.
- * Display floor No., up / down directions and easy messages.
- * Menus for settings of up/down arrows, number styles and time adjustment.
- * Display horizontally or vertically.
- * Communication Interface: RS-485.

Product Photo

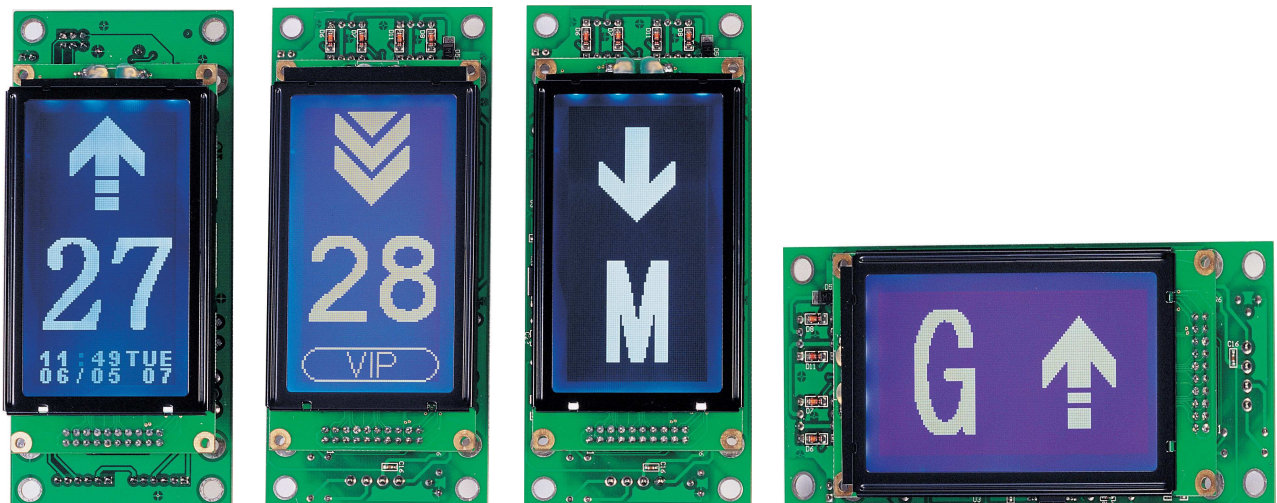

LCD Indicator Control Module Product Data Sheet

Model Name: **QCM-200AS2RS** Rev.A1

LCD Specification

LCD type	Monochrome STN LCD
LCD back-lighted type	LED
LCD screen dimension	LCD 128 x 64M Blue-W / LCD 128 x 64M Black-W
LCD viewing area	72 x 40mm
LCD dpi	128 x 64 dots
LCD Dot size	0.52 mm
LCD screen display	White words (icons) on blue / black background

Electronic Feature

Voltage Supply	DC 12 - 30 V
Current Consumption	DC 24V : 30mA DC 12V : 60mA
Start Up Power Consumption	DC 24V : 35mA DC 12V : 70mA
TVS Protection	Yes
Operating temperature	0°C - 50°C
Input Signal Interface	RS-485
Download Communication Port	RS-232
Software	QCM-200AS2 Lift LCD Editor
PCB dimension	124 x 55 (mm)

LCD Indicator Control Module Product Data Sheet

Model Name: **QCM-200AS2RS** Rev.A1

PCB Diagram

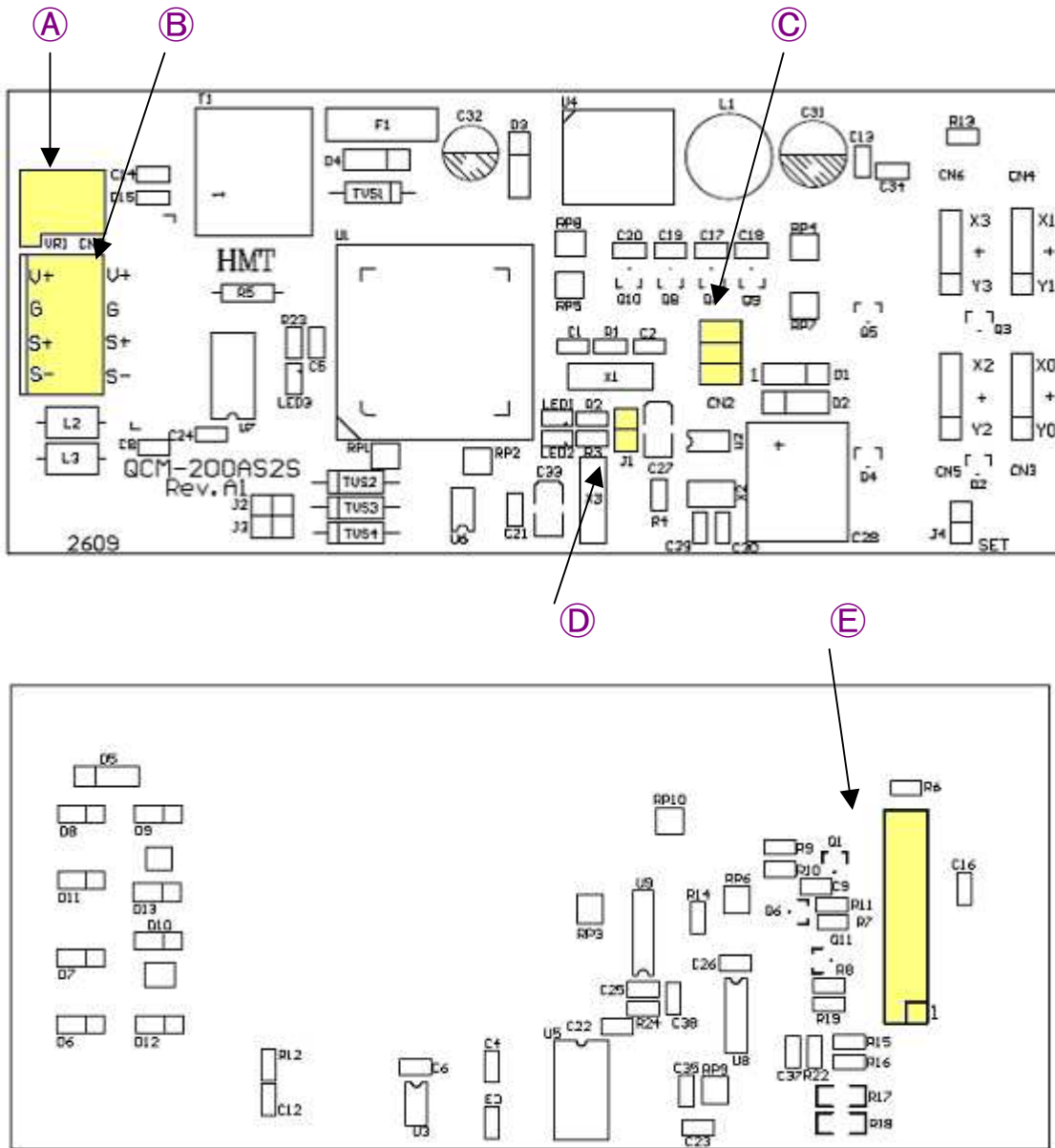

Jumpers / Connectors Description

A	VR1 : LCD Contrast Ratio Adjustment
B	CN7 : Power & Signal Connector
C	CN2 : D/L Cable Connector
D	J1 : System Reset
E	CN1 : LCD Connector

LCD Indicator Control Module Product Data Sheet

Model Name: **QCM-200AS2RS** Rev.A1

PCB Dimension Diagram

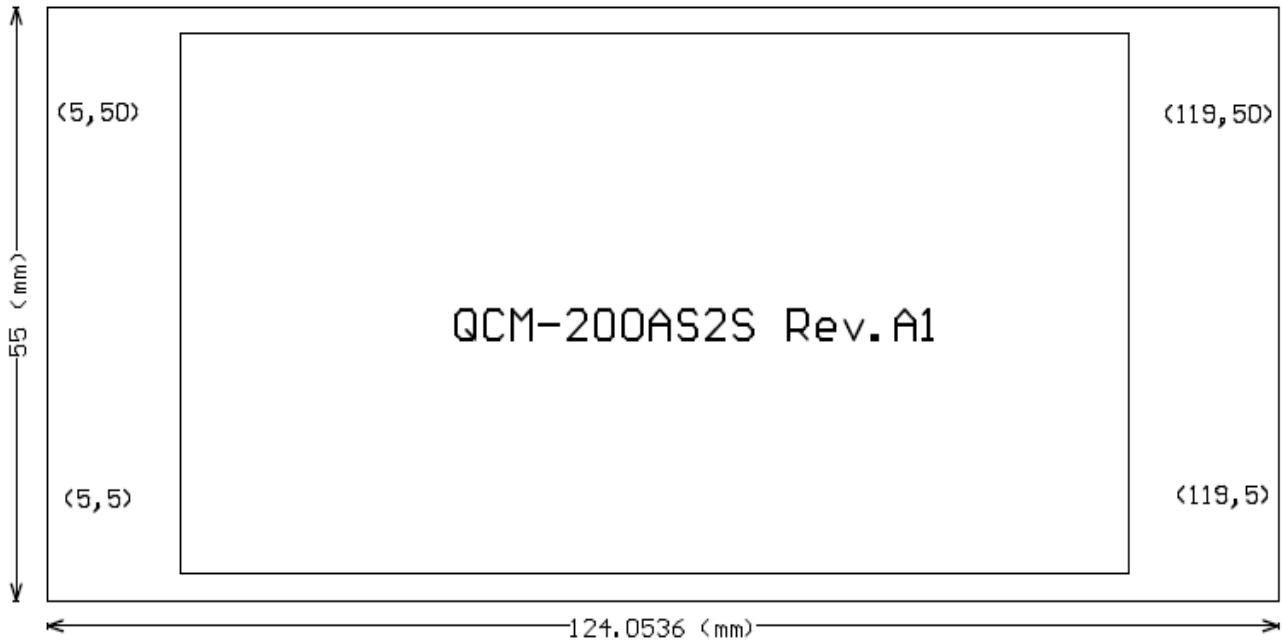

LCD Indicator Control Module Product Data Sheet

Model Name: **QCM-200AS2RS** Rev.A1

Hardware Operation Instructions

Starting Screen

When the power is on, QCM-200AS2RS will enter an elevator simulating operation screen automatically!

Horizontal Display Descriptions

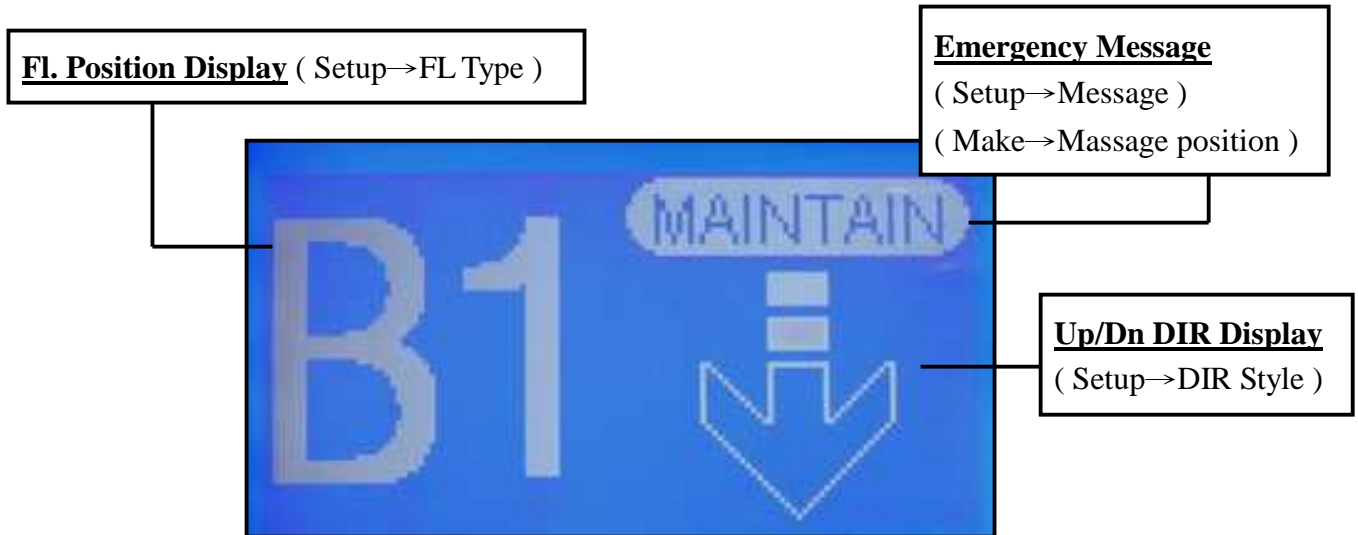

Vertical Display Descriptions

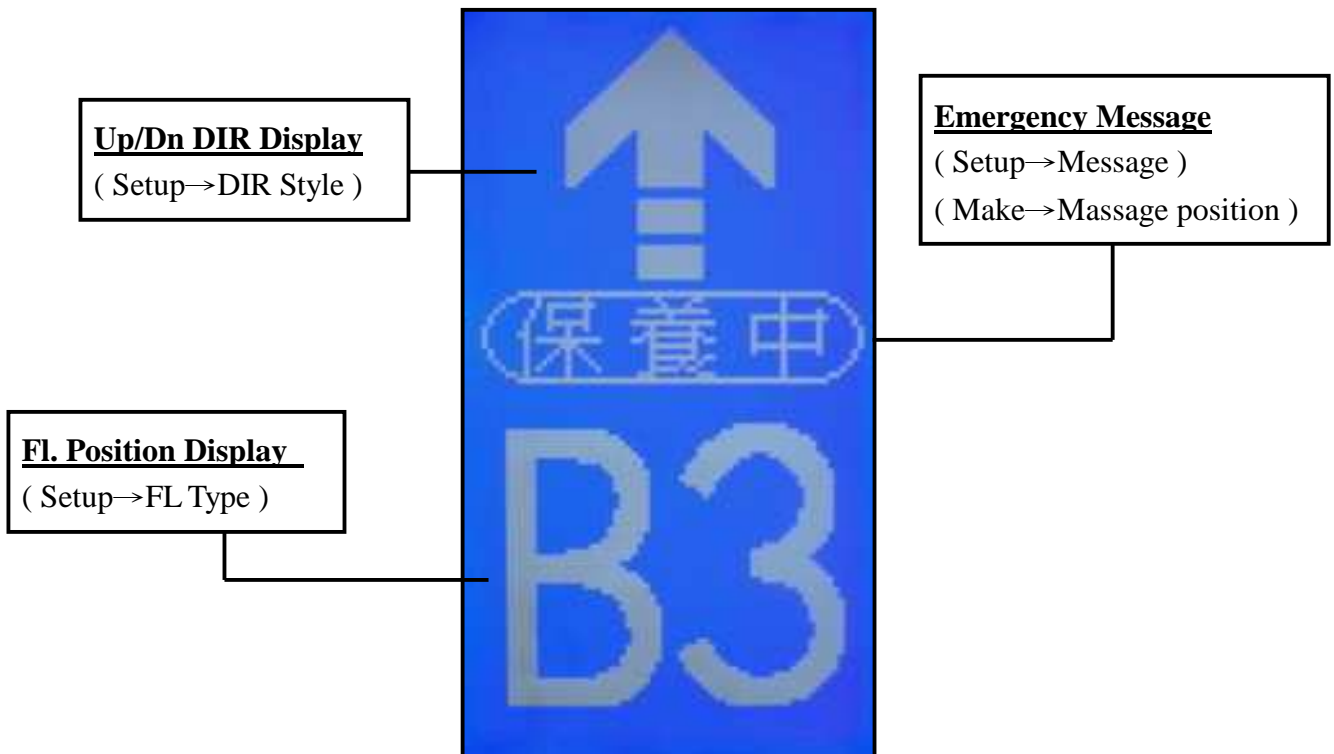

LCD Indicator Control Module Product Data Sheet

Model Name: **QCM-200AS2RS** Rev.A1

Style Position Display Descriptions

The selections like FL styles, DIR styles and Emergency messages need to be edited via QCM-200AS2 Lift LCD software after the module connects to PC. For Emergency messages, users can select the display position via the software too.

FL Style / Fl. Position Display : Built in 4 font styles (Select one style to upload).

[Note] When the default setting is in horizontal display, it'll show users the selections for FL Position Display (at the left/right side) !

DIR Style : Built in 5 arrow styles (Select one style to upload).





Message / Emergency Message : Built in 10 designed messages.

(Able to upload two display styles together at one time).

Emergency message for vertical display : Up/ Mid / Dn. Three positions to select.

Emergency message for horizontal display : Up/ Dn.Two positions to select.

Emergency Message Position List

Vertical		
Emergency Msg.-Up	EmergencyMsg.-Mid	Emergency Msg.-Dn
		
Horizontal		
Emergency Msg.-Up / Fl.-left	Emergency Msg.-Dn. / Fl.-right	
		

LCD Indicator Control Module Product Data Sheet

Model Name: **QCM-200AS2RS** Rev.A1

Data Transmission Screen Descriptions



1. After the module connects to PC, configure the transmission line on. There'll show "Reminder Message" on the LCD immediately! It means the connection between QCM-200AS2RS and PC is done successfully!!
Shown as left :



2. When PC starts uploading, the LCD will display the transmission status under "Data recv."
Shown as left :



3. After uploading, LCD will show the initial "Reminder Message" screen! It means the data from PC has been uploaded to QCM-200AS2RS successfully!
Shown as left :

Dismantle the transmission line and the LCD will display elevator simulating operation screen immediately!

[PS] : When the **transmission failure** happens to QCM-200AS2RS during connection or data transmission, **do not dismantle the transmission line!** Just **restart the power**, and the system will transmit the data again.

LCD Indicator Control Module Product Data Sheet

Model Name: **QCM-200AS2RS** Rev.A1

Software Operation Descriptions

Software Information

For providing the most convenience and efficiency, Lift LCD Editor supports the functions for uploading and editing settings via connection to PC.

Software Name : QCM-200AS2 Lift LCD Editor

Version : R2-Build70508

QCM-200AS2 Lift LCD Editor Interface

Clear ALL : Clear all data in CTBL!
 Load : Load in “qfl”, the setting file
 Save : Save the file

FL Style, Version,
 DIR Style, Emergency Message

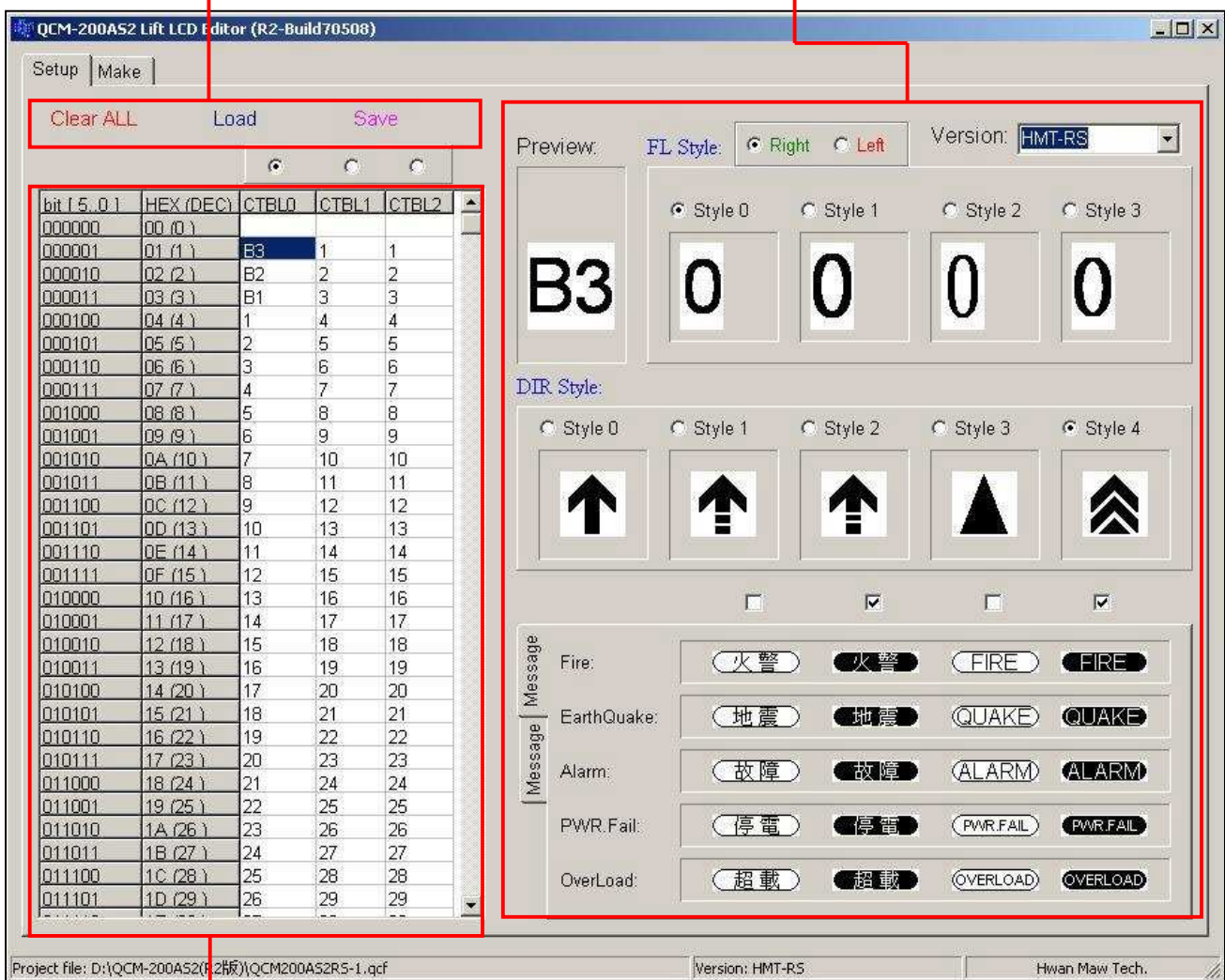

CTBL Fl. Position Code correspondences.
 Key the data in the blanks.

LCD Indicator Control Module Product Data Sheet

Model Name: **QCM-200AS2RS** Rev.A1

LCD BL Power saving · Node Address · Customer ID Code · Message position and related mode settings.

PC Connection, Data Transmission, Message box Details

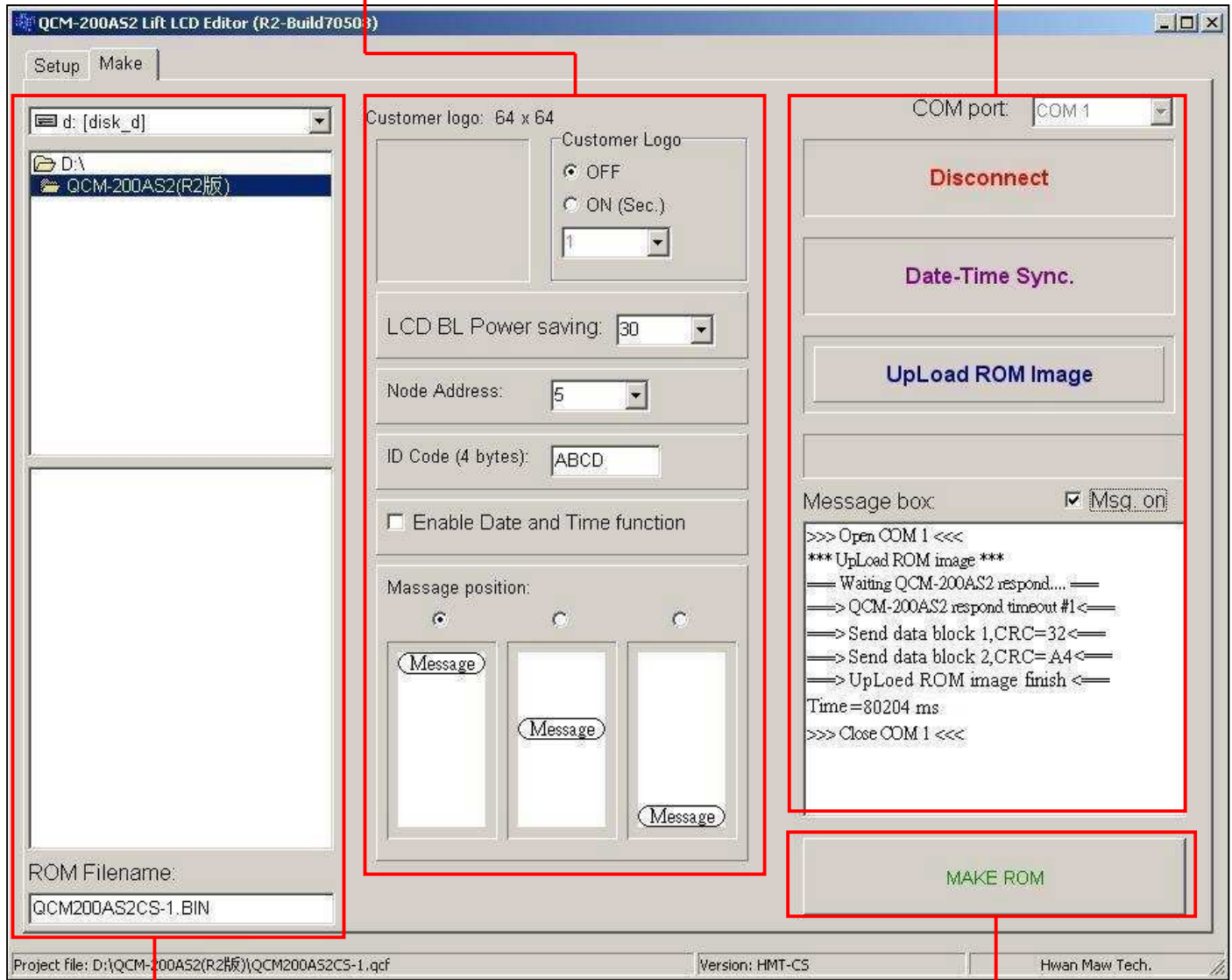

ROM file name & path

Make a ROM file

LCD Indicator Control Module Product Data Sheet

Model Name: **QCM-200AS2RS** Rev.A1

QCM-200AS2 Lift LCD Editor Operation

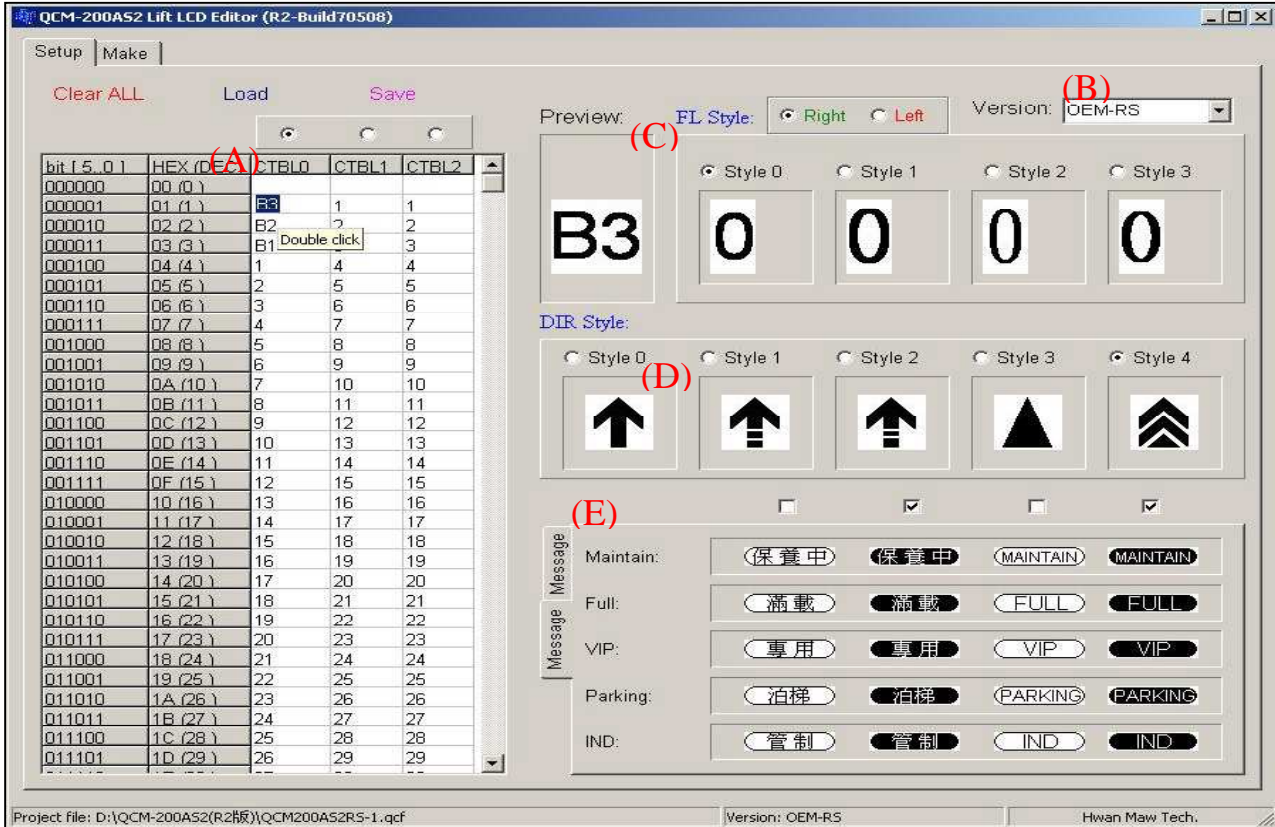

1. Setup Page : Edit Lift LCD display screen & Fl. Position Code correspondence as request!



Setup settings as shown at - (A)(B)(C)(D)(E)part in the picture above :

- (A) CTBL : Edit CTBL 、 Upload the selections for CTBL. (3 CTBLs are available at most)
Double click on CTBL to key in data. **(based on capital letters & within two digits)**
- (B) Version : Select QCM-200AS2RS version & LCD vertical / horizontal display as request.
When select LCD horizontal display, the system will start the function of “Fl. display position” (to choose the display at the left or right)!
Ex. Vertical Display : HMT-RS
Horizontal Display : HMT-RS**H** (**H at the end of RS means Horizontal display**)
- (C) FL Style : Built-in 4 font styles. Users can preview them.
- (D) DIR Style : Built in 5 styles of the directional arrows.
- (E) Message Display Style : 4 message styles (Chinese+ high light bkgnd., Chinese+ non- high light bkgnd; English+ high light bkgnd., English+ non- high light bkgnd.)Users can select two versions together. As (E) in the picture, the Chinese words are flashing with high light bkgnd on the LCD.

Built-in 10 emergency messages : Fire、Earthquake、Malfunction Alarm、PWR、Over Load、Maintain、Full、VIP、Parking and IND.

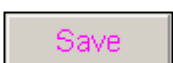
	Clear all data in CTBL.		Load in.
	Save the file. Set the extension name as .qcf		

LCD Indicator Control Module Product Data Sheet

Model Name: **QCM-200AS2RS** Rev.A1

2. Make Page : Related status settings for Lift LCD & data transmission in this step!

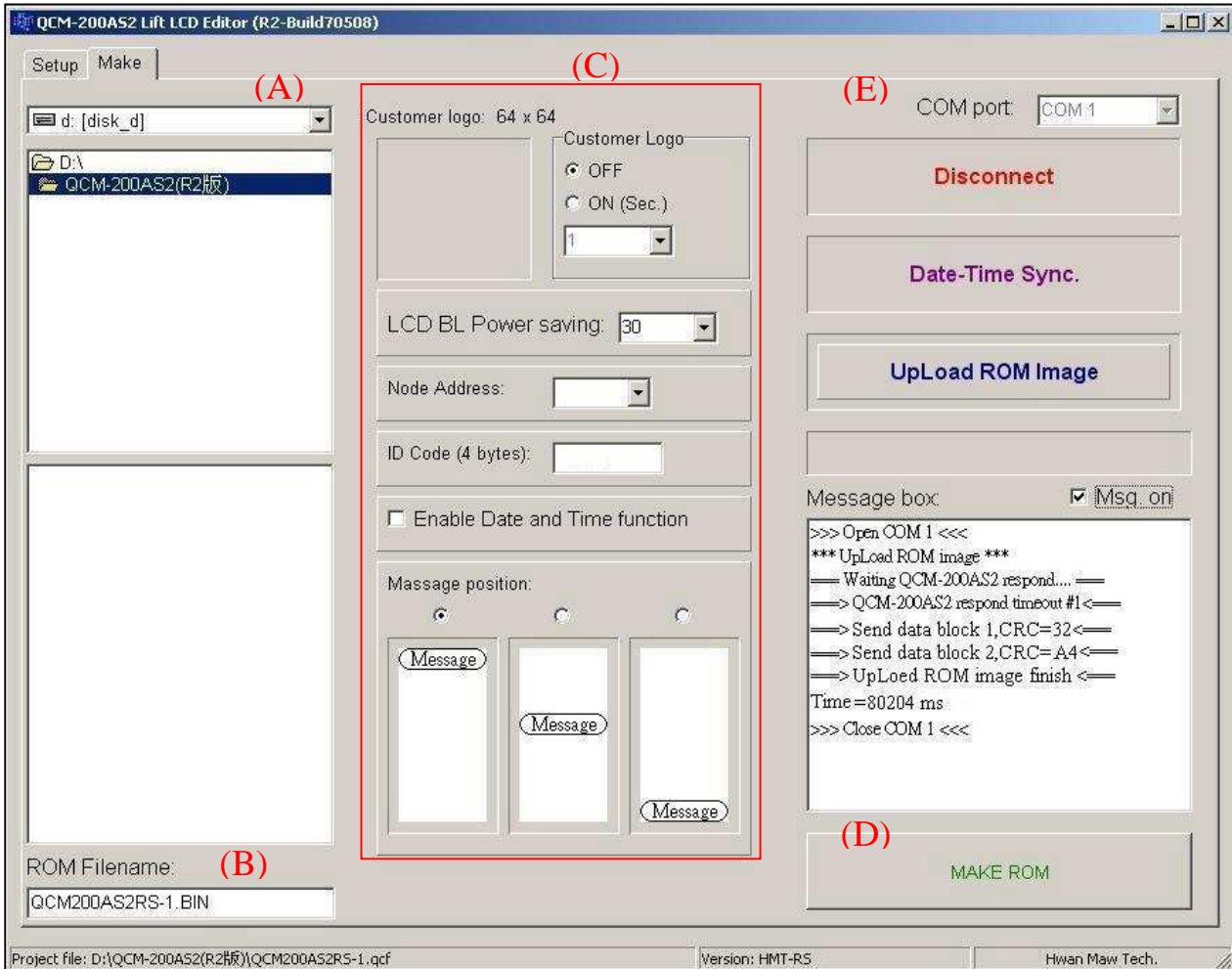

1). Make settings for these statuses – shown at (A)(B)(C)(D) in the picture above :

(A) **ROM Path** : Select the path for ROM file saving.

(B) **ROM Filename** : Build a ROM file name. (QCM-200AS2RS ROM’s extension name is BIN)

(C) **LCD BL Power saving** : Set to turn off back-lighted function in 0 sec. ~ 600 secs.

Message position : Set the position (up / mid. / dn.) of the emergency msg. on the LCD panel!

Node Address : Codes 0~63 can be set as fl. position addresses freely.

ID Code (4 bytes) : Set 4 bytes code to customize users’ setting.

(D) **MAKE ROM** : When all settings are done, make a ROM file by clicking on this button!

[Note] Before connecting or transmitting data, save the file by clicking MAKE ROM button. While saving the file, the system can also make a “BIN” ROM file for uploading as well!

LCD Indicator Control Module Product Data Sheet

Model Name: **QCM-200AS2RS** Rev.A1

2). Make PC Connection & Data Transmission- shown as (E) :

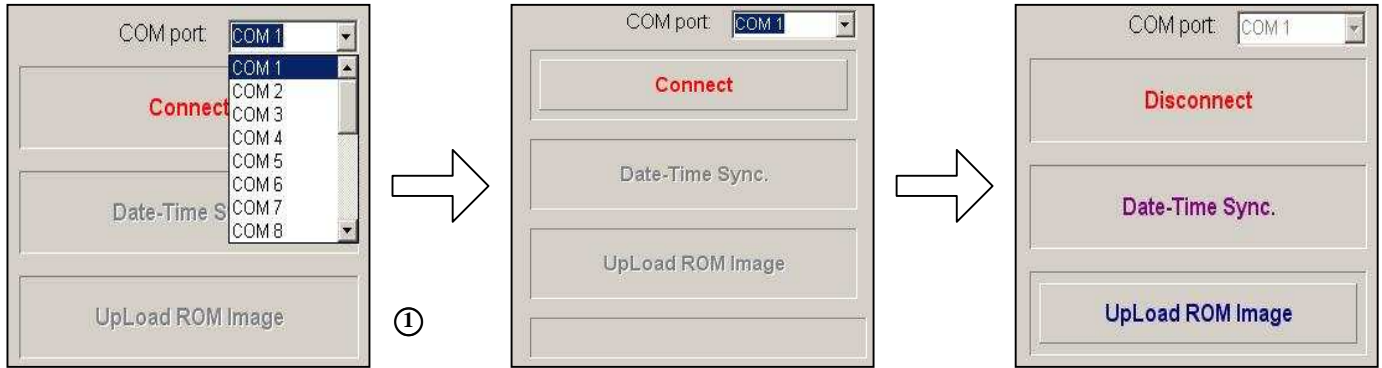

Connection- PC :

Select “COM port” first. Second, click on “Connect” to choose “UpLoad ROM Image” function.

QCM-200AS2RS :

After the connection to PC, configure the transmission line and “” will be shown on the LCD right away. It means the connection between QCM-200AS2RS & PC is ready!

② Transmission- PC :

Click on “UpLoad ROM Image” to open “BIN” ROM file and upload the file to QCM-200AS2RS.

QCM-200AS2RS :

When PC starts uploading, “transmission icon”  will be shown under  on the LCD.

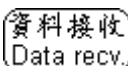
When there’s only  left on the LCD, it means the uploading procedure completes successfully! If dismantle the transmission line, the LCD will display the stand-by mode.

③ Message box : Tick “Mag.on” to show the connection, uploading... and other messages!

Message box	Descriptions
>>>Open COM1<<<	Connection Msg.
>>>Close COM1<<<	Disconnection Msg.
*** Date & Time Sync. *** ==Waiting QCM-200AS2 respond....== =>Send data block: 1,CRC = 99 <= => Date& Time Sync finish. <=	Date/Time Sync. Msg.
UpLoad ROM image ==Waiting QCM-200AS2 respond....== =>Send data block: 1,CRC = 88 <= =>UpLoad ROM image finish. <= Time=14094 ms	Upload Msg.
=>QCM-200AS2 respond timeout #1<=	Timeout Msg.

(E) PS : When the **transmission failure** happens to QCM-200AS2RS during connection or data transmission, **do not dismantle the transmission line!** Just **restart the power**, and the system will transmit the data again.

LCD Indicator Control Module Product Data Sheet

Model Name: **QCM-200AS2RS** Rev.A1

Dimension Diagram

Model No.: **QCM-200AS2RS**

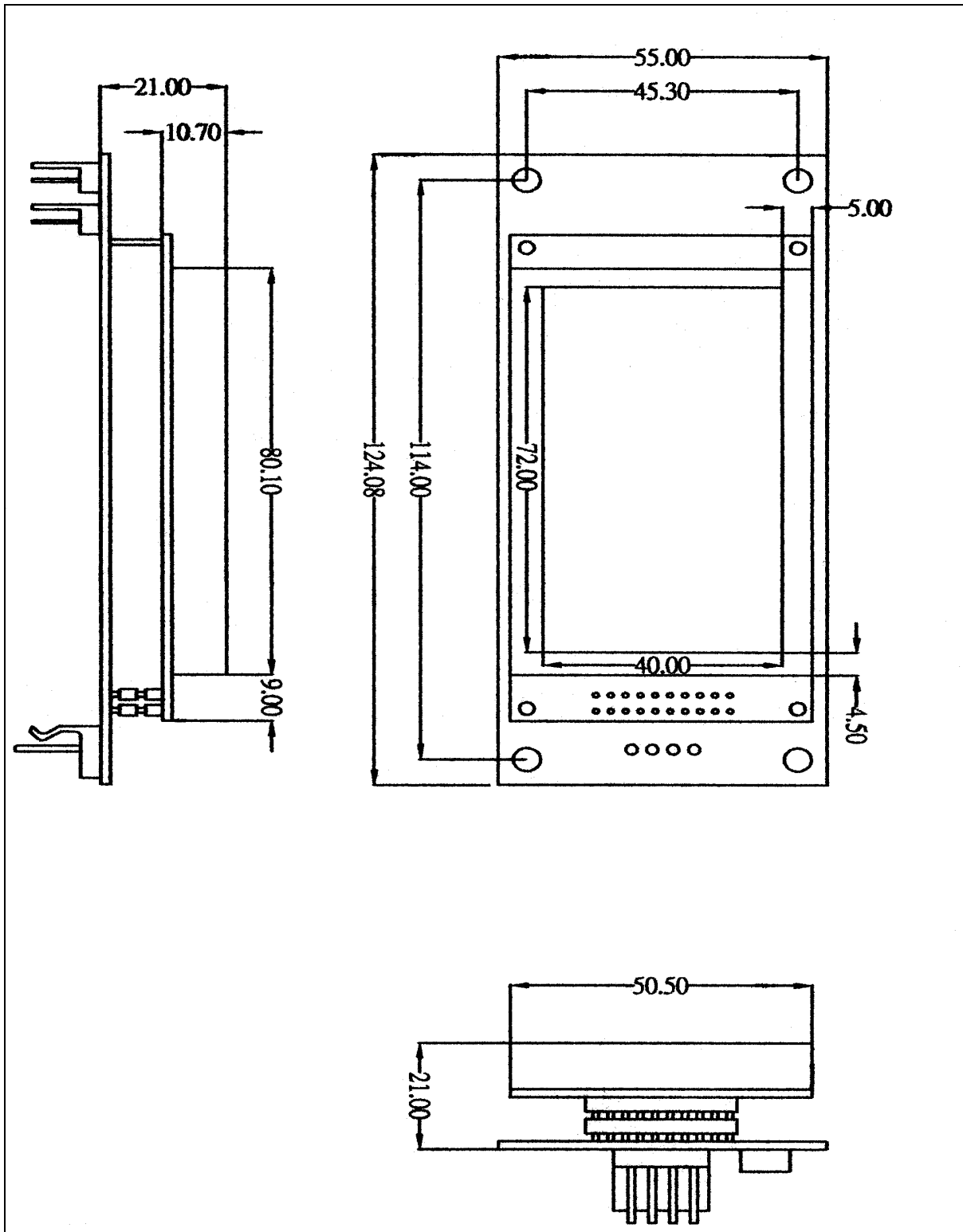

LCD Indicator Control Module Product Data Sheet

Model Name: **QCM-200AS2RS** Rev.A1

Product Information

1. Style: QCM-200AS2RS / LCD Blue-W

Spec. : Size 128 x 64 dots. / Color white on Blue / Interface: RS-485

2. Style: QCM-200AS2RS / LCD Black-W

Spec. : Size 128 x 64 dots. / Color white on Black / Interface: RS-485